

Heritage

TRADITIONS LIGHTING

Euphonious Sconce

To create this handmade brass sconce, a turned candle cup sits atop a formed extruded arm mounted to a cast backplate, indicative of fine workmanship.



Shown with a polished nickel finish.

SPECIFICATIONS

- UL listed for Dry location (may comply with Damp location when surface mounted to covered ceiling away from rain or sprinklers)
- 3" round junction box

One Size

- 3.25" w x 3.5" d x 10" h
- One Lamp
- 60-watt max* candelabra (E12) socket

Materials

- Brass

Finishes

- DABS, LABS, PUBS, PLBS, BRBS, OXBS, BZBS
- PONI, BRNI, AQNI

Other Options

- Plating in Nickel, Copper, Silver or Gold
- Custom materials and finishes available upon request

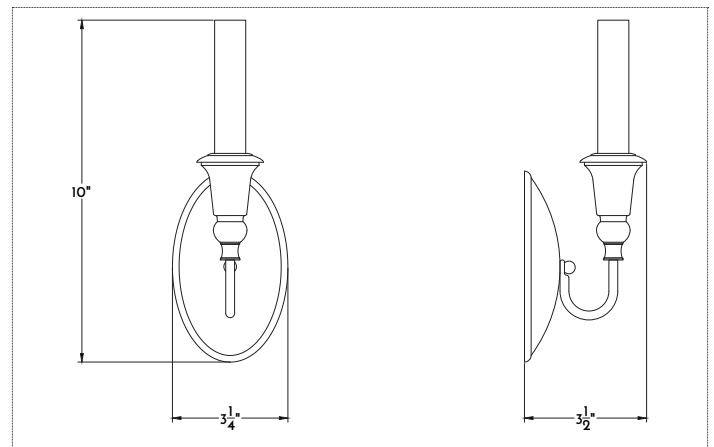

STANDARD FINISHES	BRASS		IRON		COPPER	
	DABS	Dark Antiqued*	BLIR	Satin Black, Exterior	NACP	Natural*
	LABS	Light Antiqued*	BLAQ	Black Lacquer, Interior	BZCP	Bronzed*
	PUBS	Polished Unlacquered	DWIR	Dark Wax	OXCP	Oxidized
PLBS	Polished Lacquered	NAIR	Natural*	LDCC	Leaded	
BRBS	Brushed*	RUIR	Rustic			
BZBS	Bronzed*					
OXBS	Oxidized					
	NICKEL		TIN			
PONI	Polished	AGTN	Aged			*Clear coat finish available
BRNI	Brushed	NATN	Natural*			
AQNI	Antiqued Polished	BRTN	Brushed*			

*Filament LED (2-6 watt) bulbs strongly recommended with optional wax sleeves.

